



LINEA'FLEX



FLEXIBLE ADHESIVE CORNER PROTECTOR WITH VARIABLE ANGLE ENDCAP

Applications

The Linea'Flex corner protector is the product of advanced technical expertise, combining impact resistance, flexibility and discretion, and blending perfectly with the Linea range.

It provides effective protection for all angles from 80° to 150° thanks to its flexible central part mounted on two dampers for added resistance.

Thanks to its variable angle endcap it fits to any height with maximum hygiene.

Installation is quick and easy with two strips of double-sided adhesive tape.

It blends discreetly into corridors and rooms that are exposed to repeated impacts in hospitals, clinics, retirement homes, schools, hotels, restaurants, offices and stores.

Description

- Model: Linea'Flex flexible adhesive corner protector with variable angle endcap
- Angle: from 80° to 150°
- Wing width: 45 mm (internal measurement)
- Thickness: cross-section up to 3 mm
- Length: 1.30 m, 2.00 m or 4.00 m
- Material: antibacterial and Bs2d0 fire-rated PVC, solid colour
- Surface finish: smooth
- Fixing: adhesive foam strips reinforced with SPM universal mastic glue
- Colours: 32 standard

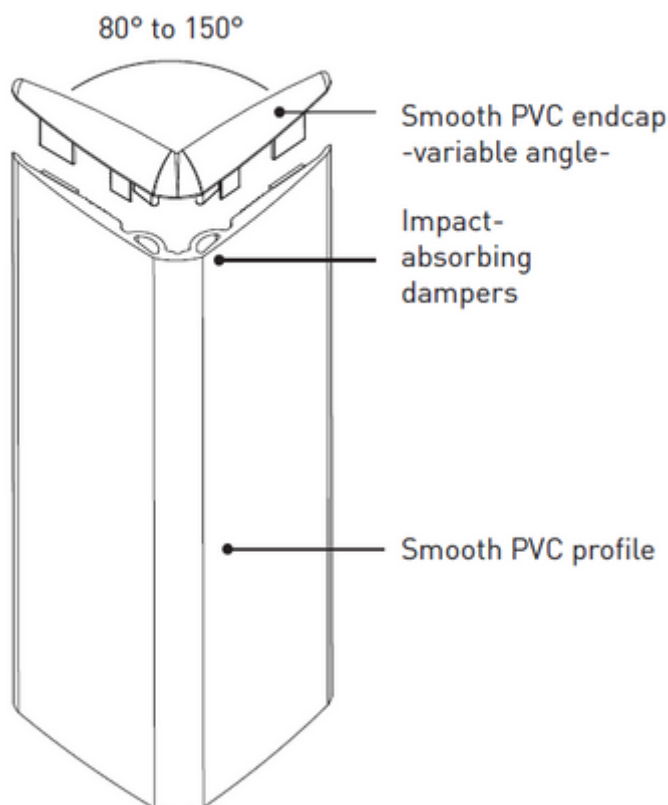

Linea'Flex
32 colours

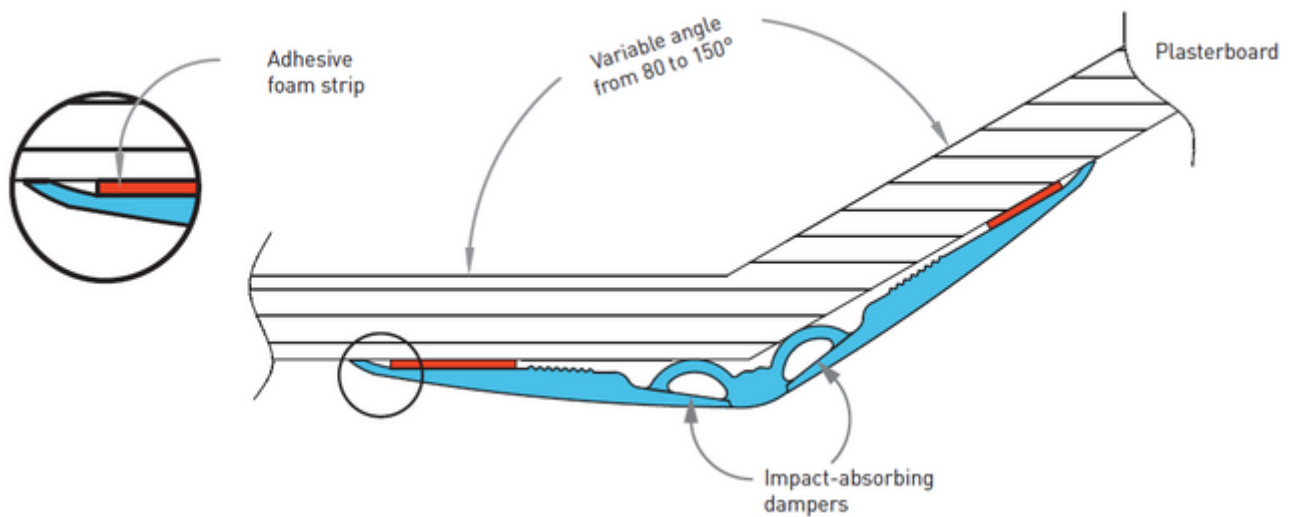
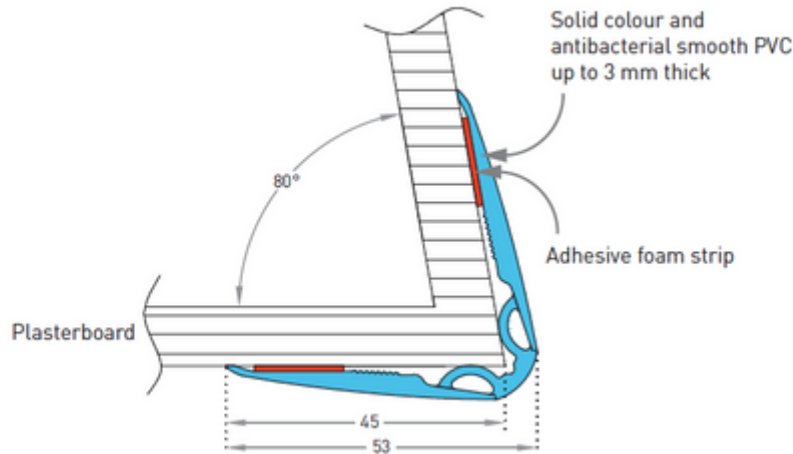

Specification

- Description : variable angle adhesive corner protector (from 80° to 150°) with a variable angle endcap (Linea'Flex as manufactured by SPM) from smooth and antibacterial PVC, 1 mm to 3 mm, achieving Bs2d0 fire rating with solid colour. A protective film is specified to minimise cleaning before acceptance. Wings are 45 mm wide (internal measurement) and the central part is reinforced with two impact-absorbing dampers. The wrenching grip is minimal by the progressive thickness (1 to 3 mm) and the bevelled shape of the wings. The corner protector is provided with 2 strips of foam adhesive tape for fixing and is finished with a smooth and bevelled PVC endcap. This adhesive corner protector achieves an impact resistance in excess of 110 Joules, i.e., an impact of more than 320 kg travelling at 3 kmh.

- Environment: no heavy metals and no substance potentially subjected to any REACH restriction are used in its manufacture, nor PBT/BPA. The calcium-zinc thermal stabilisation process is used. The emission level of volatile substance in inside air has been tested according to ISO 16000-6 and is very low (A+) according to the French regulation (23 March 2011 nr 2011-321 Decree and 19 April 2011 Order). 100% of the product are recyclable.
- Colour: selected by architects from manufacturer's standard range. The endcap colours are the same as the profile of the corner protector.
- Installation method: adhesive. SPM universal mastic glue is recommended for stronger fixing.

